

# CR Series with SmartCast® PoE Technology

CR14™ 1' x 4' Architectural LED Troffer

## Product Description

BETTER LIGHTING AND BIGGER SAVINGS.

SmartCast® Power over Ethernet (PoE) provides beautiful, comfortable and adaptive illumination with greatly simplified lighting controls. You'll cut energy costs up to 70 percent while saving money, improving aesthetics, lowering TCO and making your entire enterprise more productive.

SO SIMPLE IT JUST WORKS.

SmartCast® PoE cuts out steps and components when compared to ordinary lighting controls. That means less time and money spent designing, wiring, installing and commissioning your lighting project. And you can commission one fixture to hundreds in a single step.

READY FOR WHAT'S NEXT.

SmartCast® platform PoE is enabled to securely connect with building management systems, enterprise-wide networks and the Internet. Built on a future-ready open platform with a standards-based API, the sky's the limit for third-party cloud-based applications.

## Intelligence Summary

Embedded intelligence with microprocessor control

Firmware enables autonomous luminaire and lighting network operation

No centralized controller required

Power Over Ethernet (PoE) switches deliver power and communication (by others)

Integrated occupancy and ambient light sensors

Initial setup, configuration changes, and future upgrades available with **SmartCast Manager**

Open API with sensor data and control available with optional **SmartCast Link**

## Performance Summary

Utilizes Cree TrueWhite® Technology

Room-Side Heat Sink

**Luminaire Efficacy:** 100 LPW\*

**Initial Delivered Lumens:** Configurable from 200 to 4000 lumens to precisely match application needs

**Color Rendering Index:** 90 CRI+

**Limited Warranty†:** 10 years

\* See <http://lighting.cree.com/warranty> for warranty terms

† Based on Power Delivered to the Luminaire

## Accessories

Field-Installed		
<b>Drywall Grid Adapter</b> <a href="#">DGA-24WHT</a>	<b>Adjustable Power Feeds with Cable Support Canopy Kits</b> AC5-18/4-72-PD8-JB - Requires use surface mount kit	<b>Adjustable Cable Support Kits</b> AC5-72-PD8-JB - Requires use of surface mount kit
Platform Components		
<b>SmartCast® Manager</b> CSC-MGR - Enables initial setup, configuration changes, and energy usage visualization (REQUIRED)	<b>Cree SmartCast® Technology Configuration Tool</b> <a href="#">CCT-CWC-1</a> - Enables device and group selection in the space with visual light communication	<b>Cree SmartCast® PoE Dimmer‡</b> CWD-POE-WH <b>Cree SmartCast® Technology Face Plates‡</b> CFP-1-WH - Matching Cree face plate, 1-gang, white CFP-2-WH - Matching Cree face plate, 2-gang, white CFP-3-WH

‡ Refer to the [SmartCast® PoE Dimmer](#) spec sheet for more details

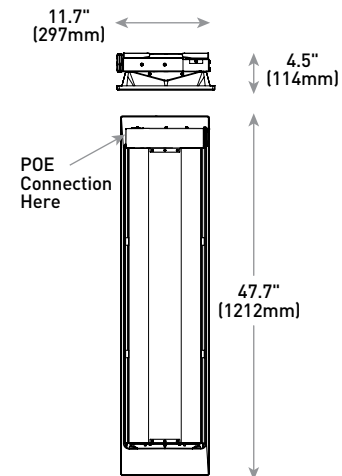

## Ordering Information

Example: CR14-40L-ACK-PoE

CR14	40L	ACK	PoE
Product	Initial Delivered Lumens	CCT	Platform
CR14	40L Configurable from 200 to 4,000 lumens	ACK Adjustable CCT: 3000K-5000K - Default = 4000K - Adjustable in 500K increments	PoE <b>Power Over Ethernet</b> - SmartCast POE



Rev. Date: V2 06/03/2016



## Cree PoE Technology

### CREE PoE TECHNOLOGY

Cree SmartCast® PoE technology seamlessly integrates hardware, software and the user experience into an intuitively simple and powerful lighting intelligence platform that saves time, money and up to 70% on energy. It eliminates the challenges of ordinary PoE lighting by automating the initial setup up of the platform and can commission hundreds of devices with the push of one button. It is open, scalable, secure and enables the Internet of Things for buildings.

### POWER OVER ETHERNET INFRASTRUCTURE (BY OTHERS)

- Delivers power and data to the luminaires with one cable from PoE switch port to luminaire
- uPoE recommended to enable full fixture output.
- Category 5e or 6a cables, shielded or unshielded. Finalize selection with infrastructure provider based on run length or other installation details
- Recommended network switches are Cisco Catalyst 4506-E, WS-C3850-24U-S, WS-C3850-48U-S  
Reference [Cree.com/smartcast](http://Cree.com/smartcast) for future additions to the compatibility list

### EMBEDDED INTELLIGENCE AND PLATFORM FIRMWARE

- Twin microprocessors and flash memory with bundled SmartCast platform firmware
- Luminaire negotiates with switch to determine maximum lumen output
  - uPoE = 4,000 lumens
  - PoE+ = 3,000 lumens
  - Network switch and luminaire communicate to prevent power from being delivered on miswired cables protecting the luminaire
- Light operates at full power output when initially connected to a compatible and configured Power over Ethernet switch
- SmartCast Manager PC Application (<https://www.creelink.com/search?qv=1&dodid=8878>) is used for One Button™ Setup of hundreds of devices at one time
  - Creates lighting network
  - Utilizes visual light communication and platform algorithms to create logical groups
  - Daylight calibration
- All settings are stored in device flash memory
- Task tuning available through SmartCast Manager

### INTEGRAL MOTION SENSOR

- Passive infrared (PIR)
- **Coverage area:** 100 sq. ft. (30.5m<sup>2</sup>) at 10 ft. (3.0m) mounting height
- Not intended to be mounted higher than 12 ft. (3.7m)
- **Operation:**
  - Grouped with a wall control: Luminaire will operate in vacancy mode (manual-on/auto-off)
  - Not grouped with a wall control: Luminaire will operate in occupancy mode (auto-on/auto-off)
- Occupancy group and other settings adjustments available through SmartCast Manager

### AMBIENT LIGHT SENSOR

- Sensor response matches response of human eye
- Not intended to be mounted higher than 12 ft. (3.7m)
- Automatic daylight calibration during One Button™ Setup
- Luminaires adjust for daylight independently to maximize savings

### FUTURE ENABLEMENT

- Firmware updates are available over the network for future function and feature improvements

## Product Specifications

### CREE TRUEWHITE® TECHNOLOGY

A revolutionary way to generate high-quality white light, Cree TrueWhite® Technology is a patented approach that delivers an exclusive combination of 90+ CRI, beautiful light characteristics, and lifelong color consistency, all while maintaining high luminous efficacy – a true no compromise solution.

### ROOM-SIDE HEAT SINK

An innovative thermal management system designed to maximize cooling effectiveness by integrating a unique room-side heat sink into the diffusing lens. This breakthrough design creates a pleasing architectural aesthetic while conducting heat away from LEDs in a temperature-controlled environment. This enables the LEDs to consistently run cooler, providing significant boosts to lifetime, efficacy, and color consistency.

### CONSTRUCTION & MATERIALS

- Durable 22-gauge steel housing with standard troffer access plate for electrical installation
- One-piece lower reflector finished with a textured high reflectance white polyester powder coating creates a comfortable visual transition from the lens to the ceiling plane
- Includes t-bar clips and holes for mounting support wires (by others)

### OPTICAL SYSTEM

- Unique combination of reflective and refractive optical components achieves a uniform, comfortable appearance while eliminating pixelation and color fringing
- Components work together to optimize distribution, balancing the delivery of high illuminance levels on horizontal surfaces with an ideal amount of light on walls and vertical surfaces. This increases the perception of spaciousness
- Diffusing lens integrated with upward-facing LED strip eliminates direct view of LEDs while lower reflector balances brightness of lens with the ceiling to create a low-glare high angle appearance

### ELECTRICAL SYSTEM

- Integral, high-efficiency driver
- **Operating Temperature Range:** 0°C - + 35°C (32°F - + 95°F)
- **Dimming:** 5% - 100%
- **Standby Power:** <1.0W

### REGULATORY & VOLUNTARY QUALIFICATIONS

- cULus Listed
- Suitable for damp locations
- Designed for indoor use
- RoHS compliant. Consult factory for additional details
- Meets FCC Part 15, Subpart B, standards for conducted and radiated emissions

**Photometry**

**CR14-40L-30K BASED ON CSA REPORT TEST #: 2362893-02**

Luminaire photometry has been conducted by a NVLAP accredited testing laboratory in accordance with IESNA LM-79-08. IESNA LM-79-08 specifies the entire luminaire as the source resulting in a luminaire efficiency of 100%.

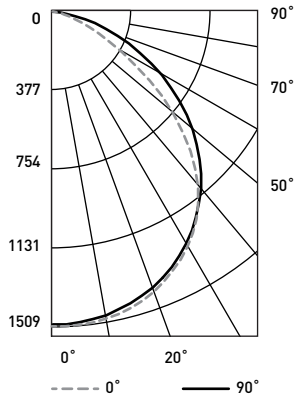

Coefficients Of Utilization – Zonal Cavity Method				
RC %:	80			
RW %:	70	50	30	10
RCR: 0	119	119	119	119
1	110	106	102	98
2	101	93	87	81
3	92	82	75	68
4	85	73	65	58
5	78	66	57	51
6	72	59	51	44
7	67	54	45	39
8	62	49	41	35
9	58	45	37	32
10	55	42	34	29

Effective Floor Cavity Reflectance: 20%

Average Luminance Table (cd/m <sup>2</sup> )			
Vertical Angle	Horizontal Angle		
	0°	45°	90°
45°	4,965	5,002	4,657
55°	4,552	4,351	3,482
65°	3,861	3,047	2,058
75°	2,869	1,618	1,114
85°	1,486	820	884

Zonal Lumen Summary			
Zone	Lumens	% Lamp	Luminaire
0-30	1,187	N/A	30.1%
0-40	1,952	N/A	49.5%
0-60	3,360	N/A	85.2%
0-90	3,945	N/A	100%
0-180	3,945	N/A	100%

Reference <http://lighting.cree.com/products/indoor/troffers/cr-series> for detailed photometric data

Recommended CR Series Lumen Maintenance Factors (LMF) <sup>1</sup>					
Ambient	Initial LMF	25K hr Projected <sup>2</sup> LMF	50K hr Projected <sup>2</sup> LMF	75K hr Projected <sup>2</sup> LMF	100K hr Calculated <sup>3</sup> LMF
0°C (32°F)	1.05	1.04	1.04	1.04	1.04
5°C (41°F)	1.04	1.03	1.03	1.03	1.03
10°C (50°F)	1.03	1.02	1.02	1.02	1.02
15°C (59°F)	1.02	1.01	1.01	1.01	1.01
20°C (68°F)	1.01	1.00	1.00	1.00	1.00
25°C (77°F)	1.00	0.99	0.99	0.99	0.99
30°C (86°F)	0.99	0.98	0.98	0.98	0.98
35°C (95°F)	0.98	0.97	0.97	0.97	0.97
40°C (104°F)	0.97	0.96	0.96	0.96	0.96

<sup>1</sup> Lumen maintenance values at 25°C (77°F) are calculated per TM-21 based on LM-80 data and in-situ luminaire testing

<sup>2</sup> In accordance with IESNA TM-21-11, Projected Values represent interpolated value based on time durations that are within six times (6X) the IESNA LM-80-08 total test duration (in hours) for the device under testing (DUT) i.e. the packaged LED chip

<sup>3</sup> In accordance with IESNA TM-21-11, Calculated Values represent time durations that exceed six times (6X) the IESNA LM-80-08 total test duration (in hours) for the device under testing (DUT) i.e. the packaged LED chip

**Application Reference**

Based on CR14-40L-30K Luminaire

Open Space					
Spacing	Lumens	Wattage	LPW	w/ft <sup>2</sup>	Average fc
8 x 8	4,000	40W	100	0.69	54
8 x 10				0.55	45
10 x 10				0.44	38
10 x 12				0.37	30

9' ceiling: 80/50/20 reflectances; 2.5' workplane, open room. LLF: 1.0 Initial Open Space: 50' x 40' x 9'

