

IMPORTANT SAFEGUARDS

When using electrical equipment, basic safety precautions should always be followed including the following:

READ AND FOLLOW ALL SAFETY INSTRUCTIONS

1. To reduce the risk of electrical shock, turn off power supply before installation or servicing.
2. This luminaire must be installed in accordance with the NEC or your local electrical code. If you are not familiar with these codes and requirements, consult a qualified electrician.
3. DO NOT lift luminaire by the power leads.
4. DO NOT carry or lift luminaire by wireform. Wireform is only for supporting luminaire while making wiring connections.

SAVE THESE INSTRUCTIONS FOR FUTURE REFERENCE

INSTALLATION INSTRUCTIONS

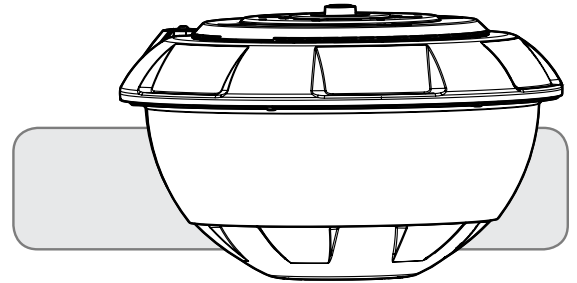

TO INSTALL:

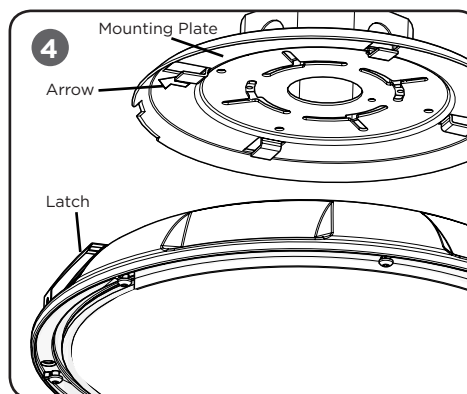
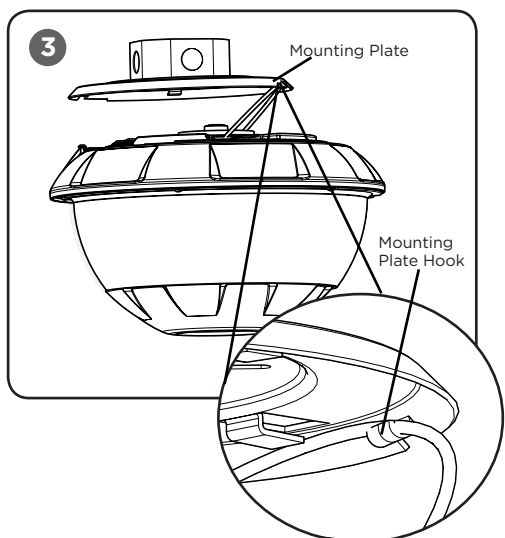
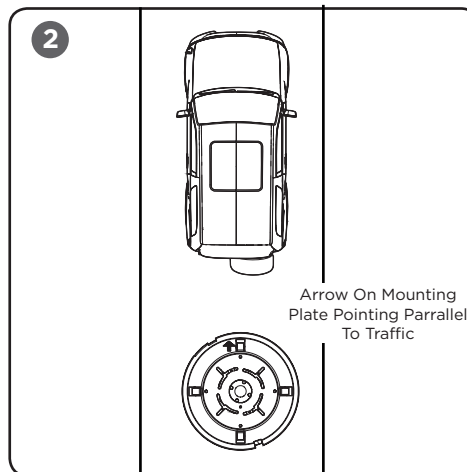
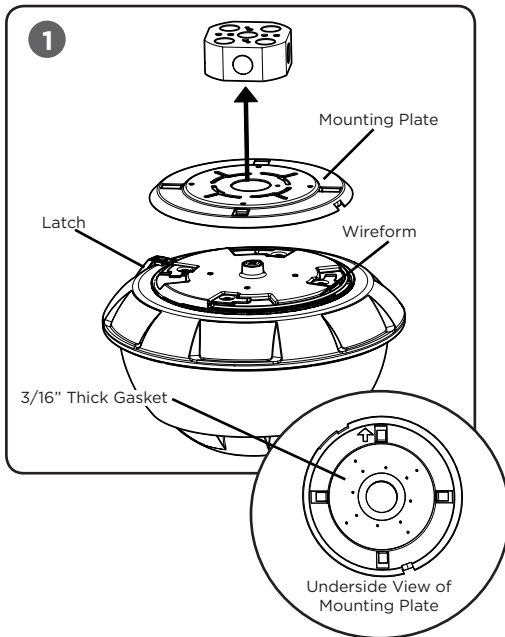

LUMINAIRE INSTALLATION

STEP 1:

Using customer supplied hardware, attach mounting plate to customer supplied junction box with the arrow on the underside of the Mounting Plate directed parallel to vehicle traffic. See **Figure 1 and 2.**

STEP 2:

Peel back and remove adhesive backing on 3/16" thick gasket, provided in hardware bag, and attach it centered to underside of Mounting Plate covering all slots and screw heads. See **Figure 1.**

STEP 3:

For hands-free wiring locate the wireform on luminaire and remove tape. Attach it to the hook on the Mounting Plate. See **Figure 3.**

STEP 4:

Make wiring connections per **"Electrical Connections"** section.

STEP 5:

After wiring connections have been made no need to remove wireform from hook. DO NOT let the luminaire hang by the power leads.

STEP 6:

Bring luminaire up to Mounting Plate, rotate luminaire until the arrow on the inside of the Mounting Plate points to the recessed area nearest to the latch on the luminaire. See **Figure 4.**

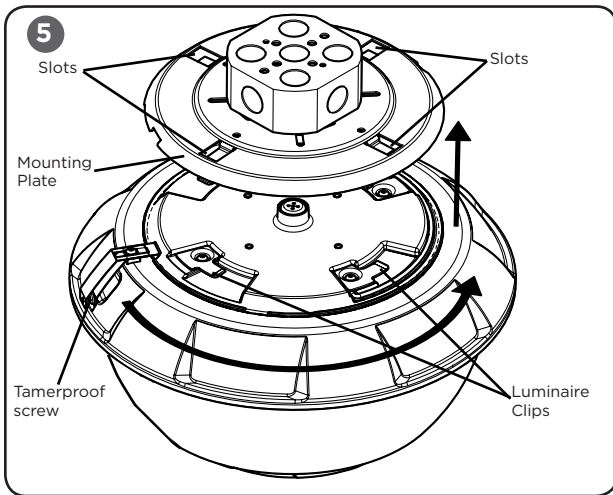

STEP 7:

Attach luminaire to the Mounting Plate by pressing up on the luminaire until the slots on the Mounting Plate engage with the clips on the luminaire and rotate until latch locks securely. See **Figure 5**.

NOTE: May require extra pressure on luminaire to engage clips into Mounting Plate slots.

NOTE: If the Mounting Plate slots become deformed during installation, slightly reopen the slots back up using a screwdriver to ensure proper install of luminaire.

STEP 8:

Lightly pull on the luminaire to verify luminaire is securely mounted.

FIXTURE SERVICING AND MAINTENANCE

STEP 1:

If supply wiring splices need to be inspected or if luminaire needs to be removed, fully loosen the tamperproof screw and slide out the latch. Then, rotate luminaire to disengage from Mounting Plate. See **Figure 5**.

STEP 2:

To re-install luminaire, when finished with servicing or maintenance, engage and tighten the latch's tamperproof screw and follow Step 1-7 in "Luminaire Installation" section above.

ELECTRICAL CONNECTIONS

STEP 1:

Make the following Electrical Connections :

- a. For 120/277V connect the black fixture lead to the voltage supply position of the junction box (Hot 1 for 208/240V wiring).
- b. For 120/277V Connect the white fixture lead to the neutral supply position of the junction box (Hot 2 for 208/240V wiring).
- c. Connect the green or green/yellow ground lead to the green wire position of the junction box.
- d. If Dimming is an option; connect the violet dimming positive lead to the supply dimming positive lead.
- e. If Dimming is an option; connect the grey dimming negative lead to the supply dimming negative lead.

