

IMPORTANT SAFEGUARDS

WARNING - Risk of Electric Shock. Disconnect power at fuse or circuit breaker before installing or servicing.

READ AND FOLLOW ALL SAFETY INSTRUCTIONS

1. It may be necessary to remove a socket mounting plate for adequate clearance.
2. Each lampholder shall be installed only in its intended manner and orientation.
3. Not all existing recessed housings that meet these requirements will be compatible with the CR6. To ensure compatibility, a test installation should be conducted.
4. Suitable for Wet Locations.
5. Do not make or alter any open holes in an enclosure of wiring or electrical components during kit installation.
6. LED Retrofit Kit installation requires knowledge of luminaires electrical systems. If not qualified, do not attempt installation. Contact a qualified electrician.
7. Min. temperature rating of 0°F or -18 °C.

SAVE THESE INSTRUCTIONS FOR FUTURE REFERENCE

RECESSED HOUSING COMPATIBILITY

- The CR6 LED Downlight is designed to install in standard 6" recessed downlight housings.
- For a list of compatible housings, visit www.cree.com/lighting.
- Compatible with most dimmers when used with multiple CR6 Downlight fixtures. Consult www.cree.com/lighting for a compatibility chart.
- Compatibility of housings not on this list may be determined by measurement of the housing as detailed in the drawing above. **(Figure 1).**

TO INSTALL:

INSTALLATION INSTRUCTIONS

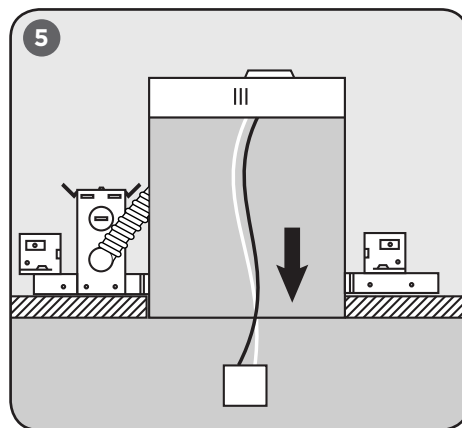
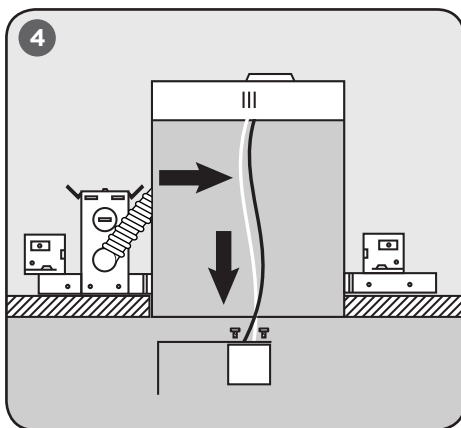
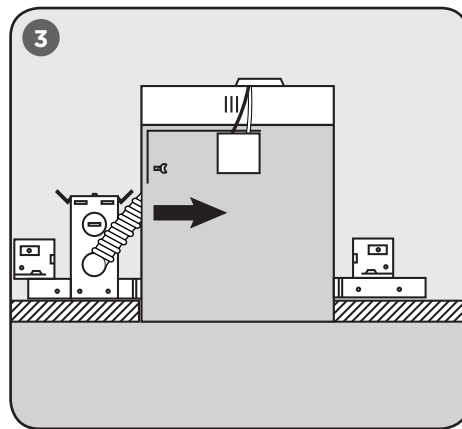
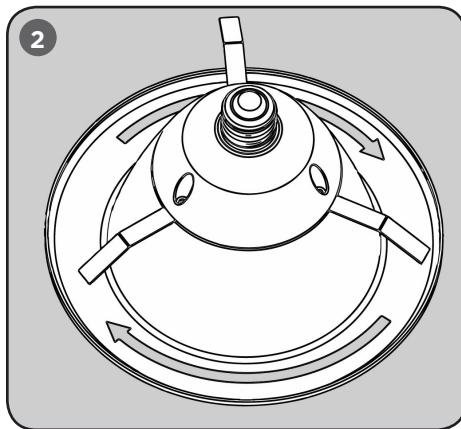
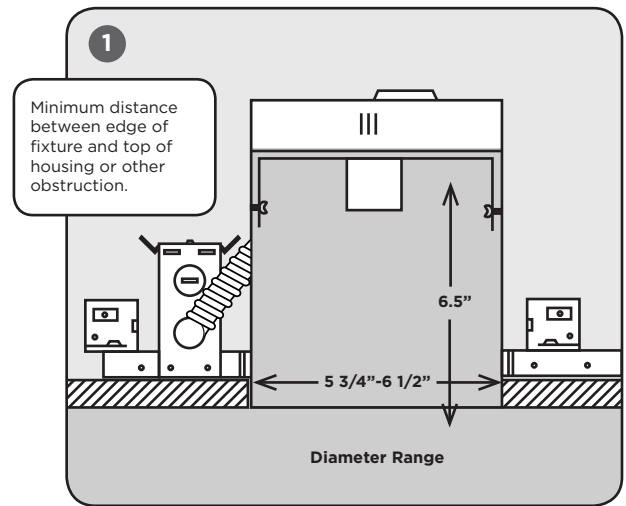

STEP 1:

Remove CR6 fixture from the packaging and rotate the "Flip Clips" clockwise until the clips are oriented directly away from the fixture. This position is the "installation ready" position. See **Figure 2**.

STEP 2:

Make sure the **POWER IS TURNED OFF** at the source to the recessed housing(s) that you are installing the fixture(s) in.

STEP 3:

Once power has been turned off, remove existing trim and bulb, revealing the existing socket.

STEP 4:

Locate the socket in your existing recessed housing and remove any screws that prevent the socket bracket from being removed. See **Figure 3**.

STEP 5:

Pull socket assembly, including the bracket, as low as possible given the existing wire length available. (May require socket plate removal) Remove any excess bracketry from socket. Care should be taken not to damage wiring during this process. See **Figure 4**.

WARNING: To prevent wiring damage or abrasion, **DO NOT** expose wiring to edges of sheet metal or other sharp objects

STEP 6:

Once you have removed the excess bracketry from the socket, you are now ready to install the CR6 fixture. See **Figure 5**.

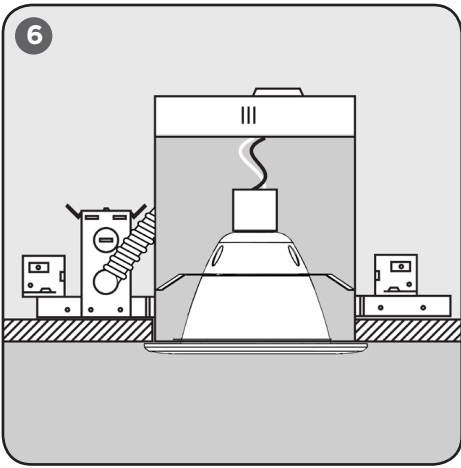

STEP 7:

If the existing socket is a GU24-style socket, or if you are converting the existing socket from an edison-style socket to a GU24-style socket, proceed to Step A under "GU24 Installation" below. (GU24 adapter only included with CR6-GU24 models.)

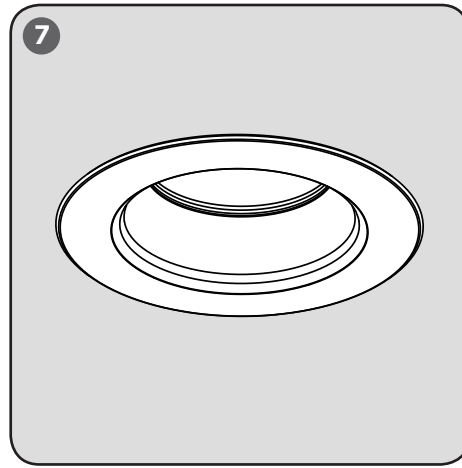

STEP 8:

Attach CR6 Downlight to recessed housing socket. Screw CR6 Downlight into the socket by turning clockwise. See Figure 6.

STEP 9:

Slide CR6 Downlight with clips, in fully-deployed position, up into the recessed housing firmly until trim ring is flush with ceiling. See Figure 7.

REMOVAL OF CR6 DOWNLIGHT

NOTE: Make sure power to fixture is disconnected before attempting to remove CR6 Downlight module from fixture.

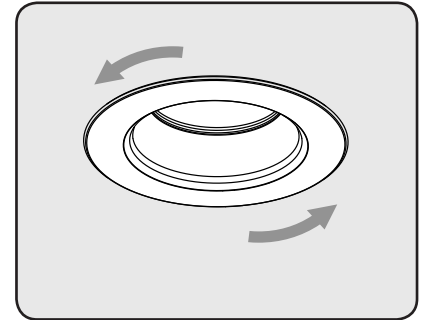

STEP 1:

To remove CR6 Downlight module, grip firmly on the trim ring and rotate 1/4 turn counterclockwise to unlock clips from recessed can.

STEP 2:

Continue to turn counterclockwise as you pull downward on the CR6 Downlight. This will disengage the clips allowing the CR6 to pull free.

STEP 3:

Detach CR6 Downlight from recessed housing socket.

NOTE: This device is not intended for use with emergency exit fixtures or emergency exit lights.

GU24 INSTALLATION (WHERE REQUIRED)

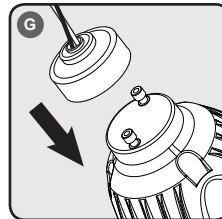
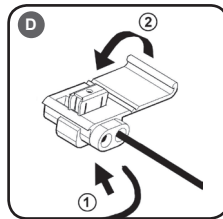
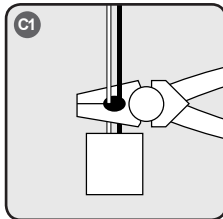
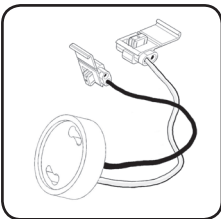

GU-24 Socket Whip (Provided with GU24 units only to convert existing edison socket fixtures to GU24)

STEP A: Remove GU-24 connector cable from box.

STEP B: Follow steps 1-6 of "INSTALLATION INSTRUCTIONS" shown on page 1.

STEP C: If the recessed housing is provided with a GU24-style socket, Skip to Step G.

STEP C1: To assemble included GU24 whip (shown above) cut wires on back side of socket. No stripping is required from remaining leads.

STEP D: Insert the input wires into the Insulation Displacement Connectors provided on the GU-24 Socket whip and clamp down on the metal u-connector until flush with the top of the plastic insulator.

STEP E: Close plastic hinged cover and snap lock.

STEP F: Place "Original Luminaire Modification Marking" label inside recessed housing adjacent to existing relamp label.

STEP G: Attach GU24 socket to the CR6 by inserting pins into the socket and twisting socket clockwise until locked.

STEP H: Continue to Step 9 shown above.

In compliance with CA Prop 65, Cree provides the following statement due to the customary electronics components used in this product. **WARNING: This product contains a chemical known to the state of California to cause cancer, birth defects or other reproductive harm.**



www.cree.com/lighting

Limited Warranty: Cree warrants to the original purchaser (the "Buyer") of the Cree® CR Series downlight purchased (the "Product"), that the Product will be free from material defects in workmanship and materials under normal use and service and conform to Cree's written specifications. This limited warranty extends for a period of five (5) years from the date of original purchase of the Product (the "Warranty Period"). There is NO WARRANTY in cases of damage to the Product in transit or damage caused by your negligence; abuse; abnormal usage; misuse; accidents; damage due to environmental, corrosive or natural elements; improper power supply; failure to follow Cree's instructions or applicable electrical codes; improper installation, storage or maintenance; damage due to acts of God; fire; vandalism; civil disturbances; power surges; alteration; mishandling; and incorrectly or improperly performing maintenance or repair by someone other than Cree or its authorized service provider. Remedy: If the Product proves defective during the Warranty Period and the Product return procedures set forth below are followed, Cree will in its sole discretion, as its sole and exclusive obligation under this warranty, refund you the purchase price of the Product, repair the Product or replace the Product without charge, F.O.B. Cree's designated facility. Proof of original purchase date (e.g., sales receipt or original invoice) is required for this limited warranty to apply. CREE SHALL NOT BE LIABLE TO BUYER, OR TO ANYONE CLAIMING UNDER BUYER, FOR ANY OTHER OBLIGATIONS OR LIABILITIES, INCLUDING, BUT NOT LIMITED TO, OBLIGATIONS OR LIABILITIES ARISING OUT OF BREACH OF CONTRACT OR WARRANTY, NEGLIGENCE OR OTHER TORT OR ANY THEORY OF STRICT LIABILITY, WITH RESPECT TO THE PRODUCTS OR CREE'S ACTS OR OMISSIONS OR OTHERWISE. This limited warranty does not cover the cost of field labor or expenses related to the repair or replacement of the Product. Cree reserves the right to utilize new, reconditioned, refurbished, repaired or remanufactured products or parts in the warranty repair or replacement process. Such products and parts will be comparable in function and performance to an original product or part, as determined by Cree in its sole discretion, and warranted for the remainder of the original warranty period. This limited warranty applies only to a Product purchased within the United States (including the lower 48 states, the District of Columbia, Hawaii, Alaska, Puerto Rico and the U.S. Virgin Islands, but excluding APO/FPO addresses that are outside of those named jurisdictions) (collectively, the "Territory"). Replacement and repaired Product or parts will only be shipped to addresses within the Territory, and refunds will only be credited to accounts located within the Territory. Making a Warranty Claim: Notice of any warranty claim should be sent to Cree at the following address: 9201 Washington Avenue, Racine, WI 53406 or you may call Cree at (800) 236-6800 to receive a RGA# and instructions for return of the Product, freight prepaid. Further Limitations: TO THE EXTENT PERMITTED BY LAW, THE LIMITED WARRANTY AND REMEDIES SET FORTH ABOVE ARE EXCLUSIVE AND IN LIEU OF ALL OTHER WARRANTIES AND REMEDIES (INCLUDING WITHOUT LIMITATION, ANY IMPLIED WARRANTIES OF MERCHANTABILITY OR FITNESS FOR A PARTICULAR PURPOSE). IF WE CANNOT LAWFULLY DISCLAIM STATUTORY OR IMPLIED WARRANTIES, THEN TO THE EXTENT PERMITTED BY LAW, ALL SUCH WARRANTIES WILL BE LIMITED IN DURATION TO THE DURATION OF THIS EXPRESS LIMITED WARRANTY AND TO REFUND, REPAIR OR REPLACEMENT SERVICE AS DETERMINED BY CREE IN ITS SOLE DISCRETION. Some states do not allow limitations on how long an implied warranty lasts, so the above limitation may not apply to you. IN NO EVENT SHALL CREE BE LIABLE FOR INCIDENTAL, CONSEQUENTIAL, INDIRECT, SPECIAL OR OTHER DAMAGES. CREE'S AGGREGATE LIABILITY WITH RESPECT TO A DEFECTIVE PRODUCT SHALL BE LIMITED TO THE MONIES PAID TO CREE FOR THAT DEFECTIVE PRODUCT. Some states do not allow the exclusion or limitation of incidental or consequential damages, so the above limitation or exclusion may not apply to you. This limited warranty gives Buyer specific legal rights, and Buyer may also have other rights which vary from state to state. Effective Date: January 1, 2013